

Intelligent O-Frame Scanner

Product Information Note

MXProLine™ will help improve your business performance in today's challenging economic environment. Including the 5080 Series Intelligent Scanners, this quality control and process knowledge system provides superior visibility into your process while it simplifies your operational efforts and is easy and cost effective to maintain and service. Improve quality, reduce raw material, services and maintenance costs, and increase production efficiency with a package of solutions that provides the lowest total lifecycle cost available

Using an intelligent network-based data acquisition and positioning system to provide significant improvements in performance and reliability, Honeywell's 5080 series scanners are compact, high-precision online scanning platforms for a wide variety of industrial applications. The scanners function as intelligent nodes on the MXProLine process control network, resulting in enhanced ease of installation and maintenance.



MODEL 3-5080-00 SUPER CLEAN SCANNER

The MXProLine Intelligent scanner combines fast scanning performance with rigid, reliable construction to provide a proven platform for measurement excellence. Its design incorporates service and maintenance features ranging from easy sensor and internal component access, to web-based configuration and diagnostic displays. Ethernet data acquisition electronics and integrated signal processing ensure continuous performance throughout the scanner's life. Specific scanner designs address various sensor models, single- or dual sensor configurations, and process environments ranging from dirty to clean room. The 5080 series are suitable for extrusion, converting, calendering and coating applications.

Features & Benefits

- Fast scanning, up to 355 mm (14 inches) per second, provides quick profile measurements that ensure responsive control and high visibility of process variations. Using Honeywell's fast-response low-noise sensors, faster measured profiles enables faster control actions and increased visibility.
- Completely new Ethernet-based data acquisition and positioning electronics for higher resolution of cross-directional features, improved reliability and lower lifetime cost of ownership.
- Precision brushless DC drive system with high resolution tachometer and digital servo controller provides sensor head positioning accuracy 1 mm (0.04 inch), resulting in accurate profile resolution and data alignment for repeatable detection of small process deviations.
- Built-in same-spot capability is provided for multi-scanner applications requiring coordination between scanning sensors, for accurate coat-weight control.
- Scanners communicate via standard Ethernet using TCP/IP protocol. Compact scanner design and network-based hardware permit rapid, trouble-free hardware installation.
- Sensor guide-tracks are bonded to the U-beams using specially designed fixtures to ensure precise mechanical alignment. Tracks are continuously cleaned by the motion of the sensor, with four, spring-loaded, Acetyl track wipers providing smooth, consistent sensor operation.
- Simple design routes cables and hoses inside scanner components, eliminating external hoses.

- Beam lengths up to 6100 mm (240 inches) allow usage in a variety of process applications.
- Optional sealed beams, cable end cooling and purge capabilities protect the scanner in harsh environments.
- Easy head separation and cover removal for quick access to sensors when needed.

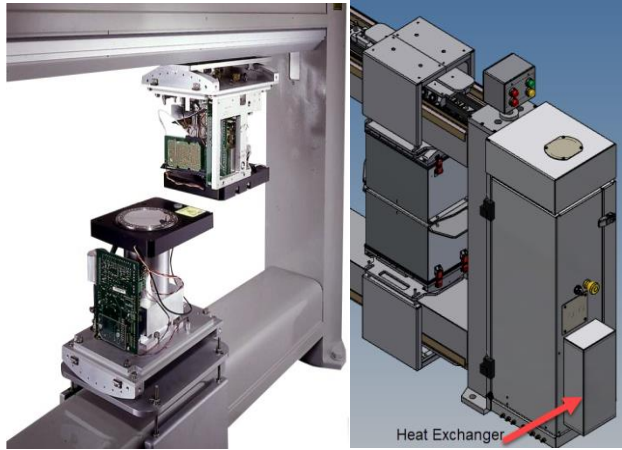

360° ACCESS

CABLE END COOLING

Description

The 5080 Series MXProLine Intelligent Scanners support the sensor heads with an O-frame construction consisting of two U-beams and two end supports.

The U-beam construction minimizes scanner frame deflection and protects all cables and drive-train components to ensure reliable operation. The standard (3-5080-00) U-beams are oriented with the upper beam open sections facing upwards and the lower beam facing downward. Equipment options are available for dirty and super-clean environments to minimize dirt buildup in the beams or trap and prevent any material from falling onto the moving web.

The sensor platform rides on durable polymer wheels with sealed, stainless-steel ball bearings that maximize durability. Driving the scanner is a fiberglass core timing belt that reduces head misalignment.

Compensation for residual scanner track misalignment is achieved with a bi-directional error-profile correction algorithm. Profile correction ensures that accurate profile measurements are available for process control and diagnostics.

The data acquisition system and a Linux single-board computer acquire sensor signals and compile scan profiles with diagnostic information in real time and periodically transmit the scan profiles to the MXProLine user’s station. The scanner supports one or two sensors and multiple secondary measurements such as Z-axis and temperature. User process inputs for line speed, web break, roll turn-up, lump detect, e-stop, and scan enable are provided in the end bell.

Completely new Ethernet-based data acquisition and positioning electronics for higher resolution of cross-directional features, improved reliability and lower lifetime cost of ownership.

All scanners in a system communicate with the Application Server via a standard Ethernet measurement LAN using TCP/IP protocol, making scanner installation inexpensive, fast and easy.

Sensor and Measurements

High speed signal acquisition, Ethernet data communications and precise spatial alignment algorithms provide fast scanning, utilizing the typical 1 ms sensor response and true edge-to-edge measurement for a precise and informative picture of product quality and profile features.

The 5080 series scanners support the complete sensor set designed for compact O-Frame scanners, including basis weight, X-ray, IR transmission and both contacting and non-contacting caliper.

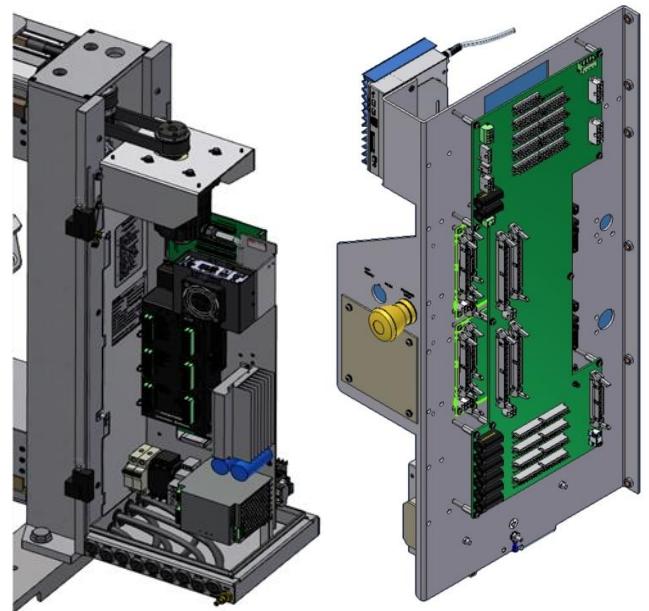

END BELL COMPONENTS - COMPACT, EASY ACCESS

Results

The design of the intelligent 5080 series O-Frame scanners reduces the total installed cost and improves reliability. The scanners have lower lifetime maintenance requirements, and have improved diagnostics via the on-board processors for easier troubleshooting and setup.

Modern components in the scanner design will extend their useful life by reducing risk of obsolescence, and isolation of the sensor data processing from the system platform allows you to upgrade at your own pace in the future. Open-source Linux operating system means independence from costly third-party components that can face obsolescence issues when PC hardware changes.

Finally, the enhanced positioning control and data acquisition systems set a new standard for performance of a scanning sensor platform, allowing you to obtain even better results from the industry’s highest-performing sensor technology.

All supported by the largest field service organization in the industry, backed by a global technical support team.



HONEYWELL MODEL 3-4202 BASIS WEIGHT SENSOR

MSS and EDAQ Info Page at 12:37 Mar 05 2018 on node 10.78.58.16

Username: _____
 Password: _____
 Login

Home

MSS Functions

Cable Status
 Data Logger
 Network Settings
 Restart MSS
 Set Boot Partition
 Set MSS Time
 Set MSS Type
 Update MSS

EDAQ Functions

Detailed EDAQ info
 Display EDAQ Data
 Display Restorator File
 Reset EDAQ's
 Update EDAQ's

Scanner Functions

Edit FC Motion XML
 MSS-EDAQ-FC Logs
 Whats Wrong Messages
 Shutdown MSS & EDAQ

1588 Info: Last Synch Message send at 12:37:47 on 03-05-18 Sync Event Number: 362
 MSS Version: R107.6 SVN: 7063 on Date: 2016-04-12 10:25:44. MSS Type: 4000CWS

device	transmit (KB/s)	recieve (KB/s)	MAC address	IP address
eth0 (RAE LAN)	0	1	00 01:c0:09:91:26	10.78.58.16
eth1 (Scanner LAN)	2	2	00 01:c0:09:91:27	192.168.0.1
eth1.10 (VLAN)	0	0	00 01:c0:09:91:27	192.168.1.1

Active Hosts

Name	IP Address	Description	Process Status	Function Code	Position Code	Web Active	SSH Active	EDAL Active
fc	192.168.0.2	Frame Motion Controller	🟢	2	2	y	y	y
mss	192.168.0.1	Measurement Sub System	🟢	1	1	y	y	y
sensor-edaq2	192.168.0.4	eddaqSENSOR	🟢	9	4	y	y	y
switch	192.168.0.40	-	🟡	-	-	y	-	-

WEB PAGES – DIAGNOSTICS AND SETUP

Specifications

PARAMETER	SPECIFICATION
Scanner Weight	173 lb. + 2 lb./in [91 kg] + [0.4 kg/cm]
Maximum Beam Length	6100 mm (240 in)
Scanning Speed	Variable to 355 mm (14 in) / sec
Pass Line Adjustment	Single sensor 0° to 55°, Dual sensors 0° to 5°
Maximum Ambient Temperature	60° C
Maximum Humidity	85% relative humidity non-condensing
Scanner Power	115 or 230 Volt AC 50/60 Hz
Certifications	CSA / UL / CE

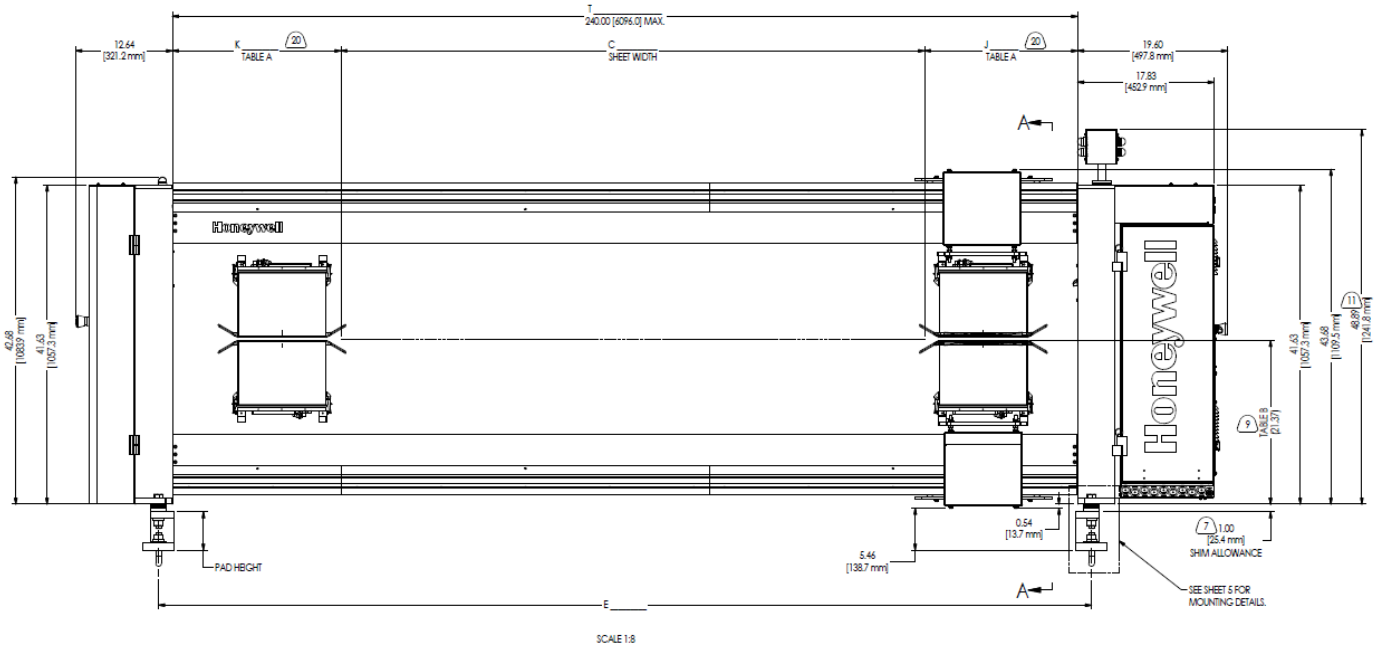
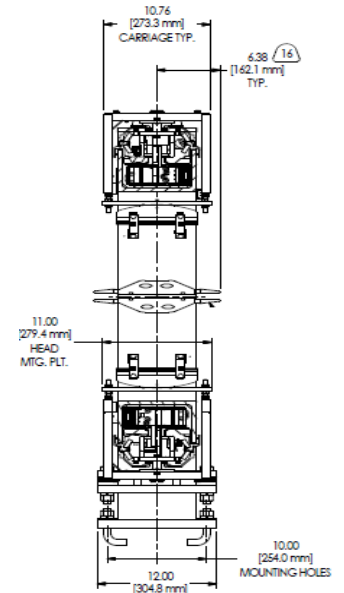

For More Information

Learn more about Honeywell's Products and Solutions at www.honeywellprocess.com, or contact your Honeywell Account Manager, Distributor, or System Integrator.

Honeywell Process Solutions

1250 West Sam Houston Parkway South
Houston, TX 77042

Honeywell House, Skimped Hill Lane
Bracknell, Berkshire, England RG12 1EB UK

Building #1, 555 Huanke Road,
Zhangjiang Hi-Tech Industrial Park,
Pudong New Area, Shanghai 201203

PN-xx-xxx-ENG
March 2018
© 2018 Honeywell International Inc.

